

RSF111K2 1U KB drawer installation manual



Included in this package

(1) RSF111K2 Keyboard Drawer ❶

(2) Front Ear L Bracket ❷

(2) Rear Mount Extension Bracket Long ❸

(2) Center / Rear Mount Extension Bracket ❹

(2) Anchor Bracket w/ (4) M4 Screw.

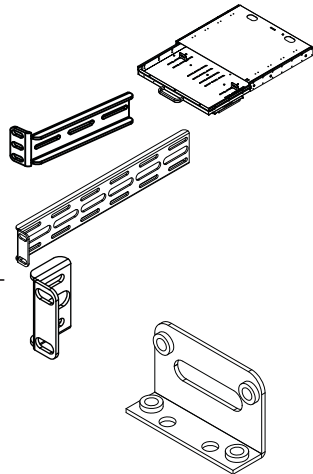

(12) M4 x 6 Flat Head Screw

(8) #10-32 x 5/8 Rack Screw

(8) #12-24 x 5/8 Rack Screw

(1) Cable Strap.



Installation Steps

1. Secure (2) Front Ear Bracket to the Left and Right side of the drawer. (Figure 1).

Figure 1

2. Install the keyboard drawer into your cabinet with correct 10-32 or 12-24 rack screw provided (Figure 2).

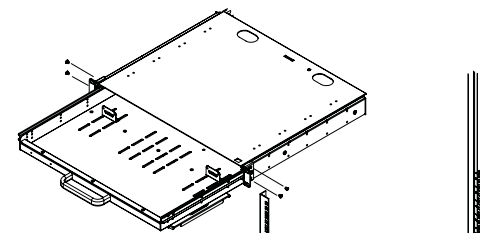

Figure 2

3. Secure rear extension bracket with (4) M4 flat head screw provided, you can adjust it according to your cabinet length. (Figure 3)

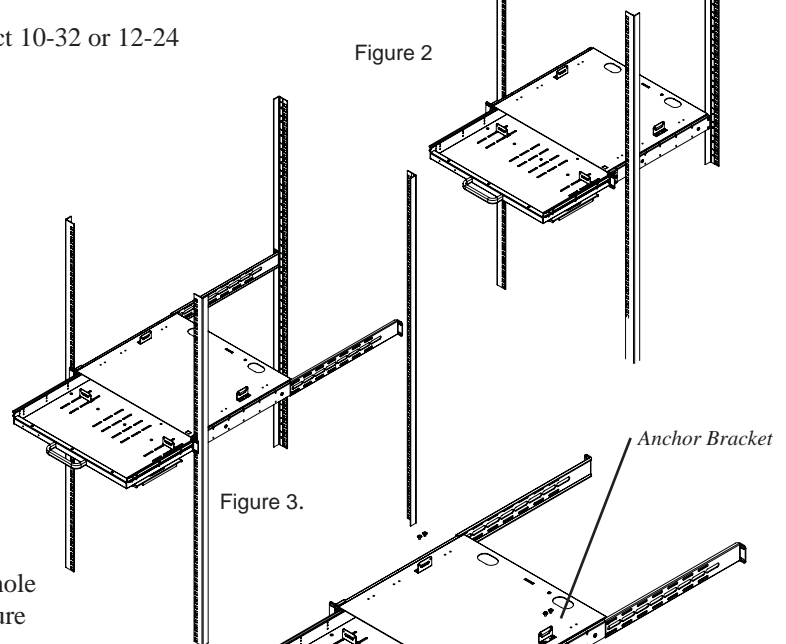

Figure 3.

4. Optional: Install 2 anchor bracket with (2) mounting hole located on top cover. Use it with cable strap include to secure your equipment. (Figure 4)

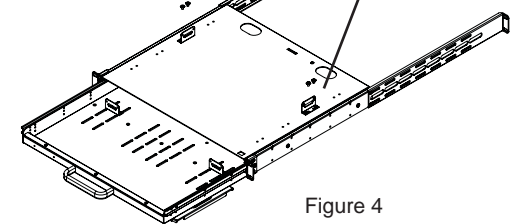
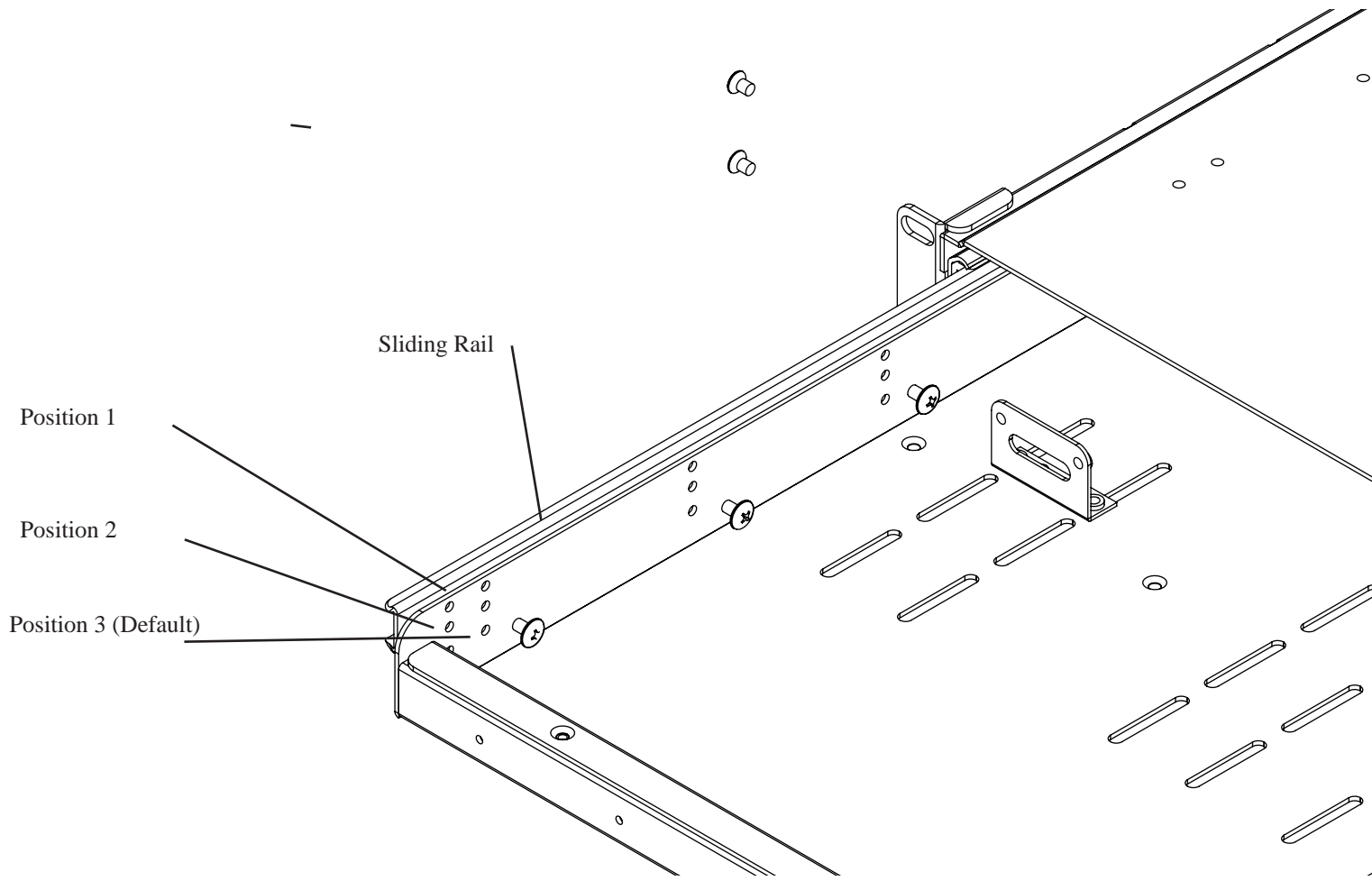

Figure 4



Change your keyboard tray position for type of keyboard you want to use. The default position is for ultra compact keyboard. Position 2 is for compact keyboard. Position 1 is for high profile compact keyboard. If you choose to use position 1 location, you might need to remove your mouse pad tray option in order to fit into 1U space. If you have 2U space available, you can keep the mouse pad tray at position 1 setting.

To change keyboard tray position, you need remove (8) M4 screws located on the slide rail.

You can shift up or shift down your keyboard tray from the rail. Adjust according to height of your keyboard.

Secure all (6) M4 screw to lock keyboard tray in place.

Installation complete.